

MUSEUM_{OF} THE ROCKIES

Rockets: Stomping Down!

Mission:

Discover the action and reaction of a Stomp Rocket. Never point a rocket at anyone and always wear your safety glasses.

Experiment:

Step 1: Put on your safety glasses.

Step 2: Place the rocket on the launching device.

Step 3: Step on the stomp pad and watch what happens!

Questions:

1. What is the first action? (Stepping on the stomp pad.)
2. What is the first reaction? (Air from the stomp pad being compressed.)
3. What is the second action? (The compressed air expanding.)
4. What is the second reaction? (The rocket taking off from the launch pad.)

Theorize:

- A. What is the rocket's fuel?
- B. Where does the fuel come from?
- C. How could you make the rocket soar higher? Lower?

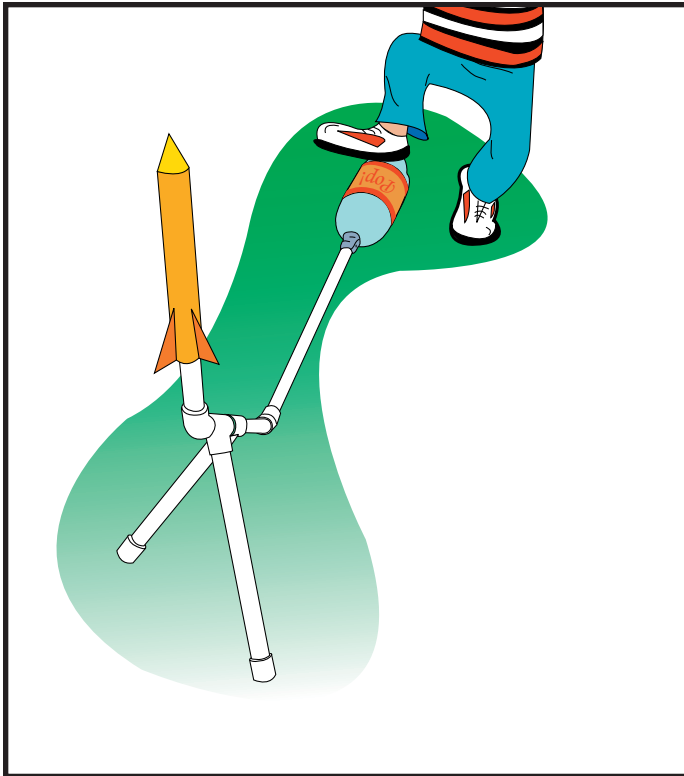

Rocket Activity

Pop! Rocket Launcher

Objective

To construct a simple air pressure launcher for paper rockets.

Description

Students stomp or jump on an empty 2-liter soft drink (“pop”) bottle and force the air inside through connected plastic pipes to propel a paper rocket.

National Science Content Standards

Physical Science

- Position and motion of objects
- Motions and forces

Science and Technology

- Abilities of technological design

National Mathematics Content Standards

- Measurement

National Mathematics Process Standards

- Connections

Materials

- Empty (and rinsed) 2-liter plastic soft drink bottle
- 2 1/2” PVC tee connectors
- 2 1/2” PVC 45 degree elbows
- 2 1/2” PVC caps
- 1- 5’ length of 1/2” PVC pipe
- Duct tape
- Ruler
- Balloon or basketball hand pump
- Rubber stopper or cork (#1 size, 1 hole)
- Eye protection for anyone near launcher

Management

The Pop! Rocket Launcher, although fun for all students, is an ideal launcher for younger students because they love to stomp on the bottle to launch the rocket. The launcher can be used for any kind of large paper rocket, including the high-power paper rockets described on page 91. However, the Pop! Rockets described in the activity starting on page 66 are well-suited for this group of students because of their relatively easy construction.

Take the shopping list on the next page to the hardware store to obtain the PVC parts. The PVC pipe will be cut into smaller pieces. Use a fine-tooth saw or a PVC cutter (available from the hardware store). The PVC parts do not have to be cemented together. Friction will hold the parts with occasional adjustment. Leave the label on the bottle. This gives students a target to aim for when stomping. If the ends of the bottle are accidentally squashed, the bottle becomes difficult to reinflate and has to be replaced. If you prefer to remove the label, use a marker and draw a bull's-eye on the side of the bottle.

The PVC legs are of different lengths. The leg nearest the bottle is the shortest. Angling the legs to the sides results in a tripod arrangement that supports the launch tube (the part the paper rocket slips over for launch (part #11). The launch tube can be aimed at different angles by tilting to one side or another. Rotating the entire launcher horizontally changes its direction.

When using the launcher, place it in an open space. It can be used inside a gymnasium or cafeteria. If using inside, aim the launch tube at a low angle towards a far wall. Select a target to aim for. If using outside (choose a calm day), the launcher should be aimed at a clear area. For fun, place a basketball in the landing zone. Tell students to imagine the ball is the planet Mars (it's the right color!) and have them launch their rocket to Mars.

Make sure the student doing the launching and any other students near the launcher are wearing eye protection. Do not permit any students to stand in front of the launcher or in the landing zone while "launch operations" are taking place.

Procedure

1. Cut the PVC pipe into the following lengths:

- #3 - 50 cm
- #5 - 18 cm
- #7 - 4 cm
- #9 - 4 cm
- #11 - 25 cm
- #12 - 20 cm
- #14 - 25 cm

The part numbers indicate where each piece is placed in the assembled launcher diagram below.

2. Insert the end of pipe #3 into the neck of the bottle and tape it securely with duct tape.
3. Follow the construction diagram below for assembly of the launcher. Match the pipe lengths with the parts numbers.
4. Swing the two legs outward or inward until each touches the ground to form the tripod. The launcher is ready for use.
5. Insert the inflator tube of the balloon pump/ basketball hand pump into the hole of the stopper.

Using the Pop! Rocket Launcher

1. Place the launcher in an open space and tilt

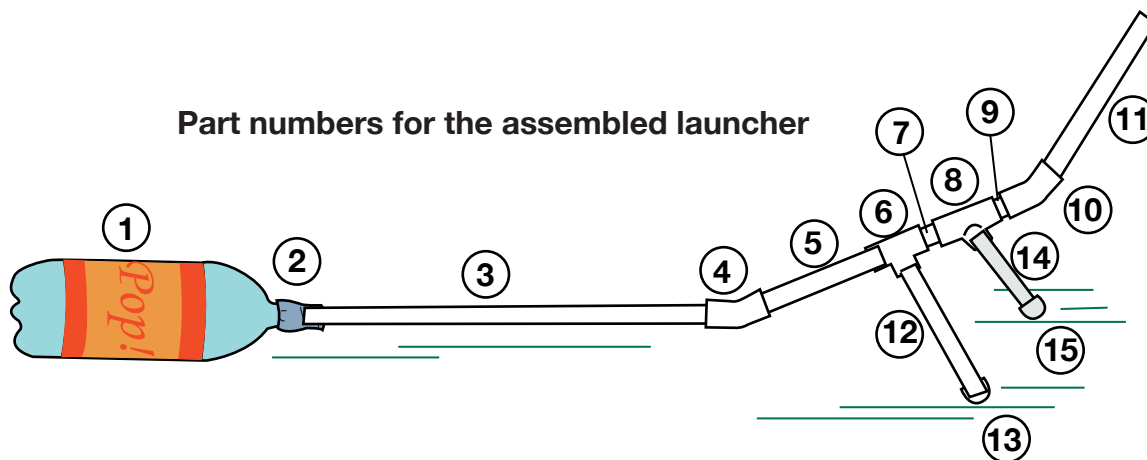



- the launch tube in the desired direction. If shooting at targets, have each student aim the launcher for his or her flight.
2. Make sure the flight zone is clear of anyone who might be hit by the rocket.
 3. Have the student put on eye protection and do a countdown to zero.
 4. The student should stomp or jump on the label of the bottle. This will force most of the air inside the bottle through the tubes and launch the rocket.
 5. While the student is retrieving the rocket, have the next student reinflate the bottle by pushing the rubber stopper attached to the hand pump into the end of the launch tube. Pumping will pop the bottle back into shape.

6. When the flight zone is clear, have the next student put on the goggles, slide the rocket on to the launcher, aim the launcher, do the countdown, and stomp on the bottle.

Tip Have a couple of spare bottles and the duct tape ready for a quick change-out in case the launcher bottle becomes damaged and no longer usable.

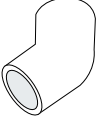
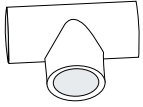
Shopping List

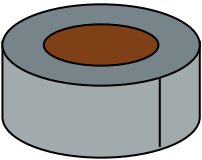
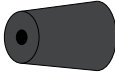
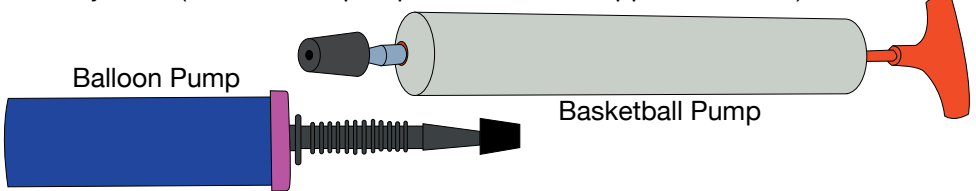
<p>1 - 1/2" (PVC) 5 feet long (to be cut into smaller pieces) Hardware store or plumbing supply</p> 	<p>2 - 1/2" 45° Elbow (PVC) Slip* Hardware store or plumbing supply</p> 	<p>2 - 1/2" Tee (PVC) Slip* Hardware store or plumbing supply</p> 
<p>2 - 1/2" Caps (PVC) Slip* Hardware store or plumbing supply</p> 	<p>Duct Tape Hardware store</p> 	<p>1 #1, 1-hole Rubber Stopper May be available from hardware store or from school science supply</p> 
<p>Balloon or Basketball Pump Toy or variety store (two different pumps shown with stoppers attached)</p>  <p style="text-align: center;">Balloon Pump Basketball Pump</p>		

* Slip means a joint connected with cement rather than threads.

READ INSTRUCTIONS BEFORE ASSEMBLING

Contains information for all Stomp Rocket® Kits. It may include instructions for kits that you may not have purchased. Save instructions for future reference.

UNIVERSAL LAUNCH ASSEMBLY

For ages 12 and up.

- 1.** On a flat surface place Leg "C" (slots) over leg "B" (notches) leaving space for leg "A" to fit in between.

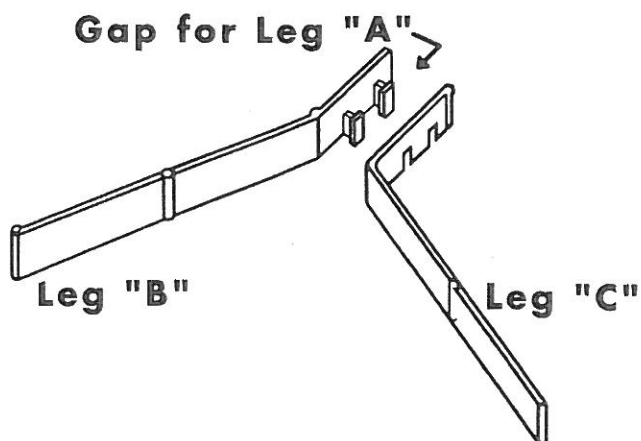

- 2.** Slide Leg "A" **BETWEEN** Leg "B" & Leg "C". Push down on Leg "A" to a tight fit.

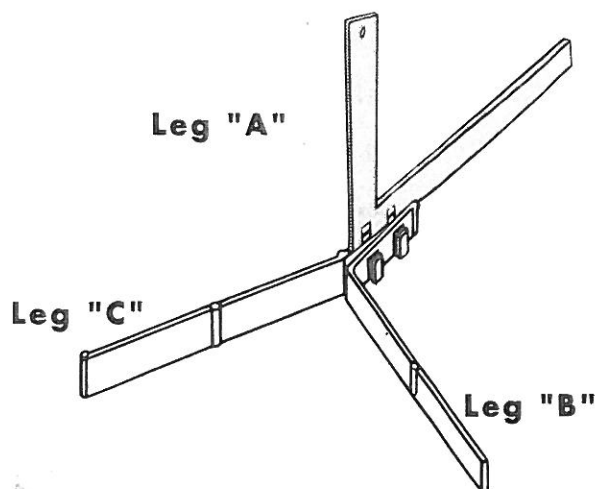

- 3.** Launch Tube & Hose must be attached so that black tubing runs vertical and parallel to leg "A" of Launch Stand as shown in illustration. Insert Carriage Bolt as shown through Hose, Launch Tube, and Leg "A" Upright. Screw on wing nut and tighten.

- 4. Find a Launch Site:** find a wide open level area to use as your launch site. Look up and make sure there are no trees or power lines close by. Set the launch stand in the middle of that area. Is the launch tube laying flat along leg A? Is the launch pad flat on the ground. Make sure Launch Hose is not twisted. Load a rocket by sliding it onto the launch tube. **Read warning on cover and you're ready to go.**

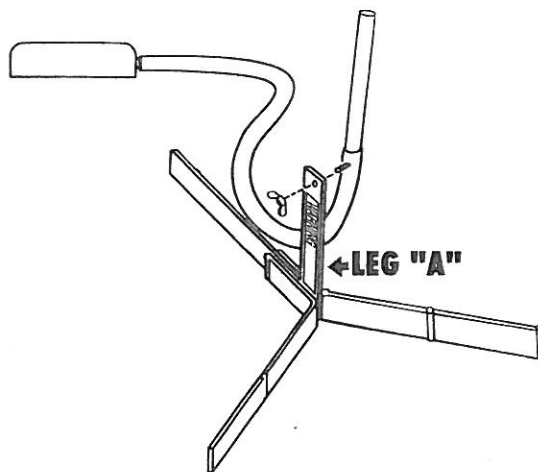

WARNING:

**CHOKING HAZARD— Small Parts
Not for children under 3 years**